



دانشگاه صنعتی شاهرود  
سایت علمی استادان



انجمن مهندسی  
ساخت و تولید ایران

1



دانشگاه شاهرود  
واحد صنعتی  
گروه مهندسی ساخت و تولید



دانشگاه آزاد اسلامی  
واحد نجف آباد

( )

[a.hojati@yahoo.com](mailto:a.hojati@yahoo.com)

(Gripper)

(PCI)

CATIA      ActiveX      Visual Basic

PCI

(Industrial Automation )

PCI



دانشگاه صنعتی شاهرود  
سازمان مهندسی



انجمن مهندسی  
ساخت و تولید ایران



1



دانشگاه آزاد اسلامی  
واحد نجف آباد

( )

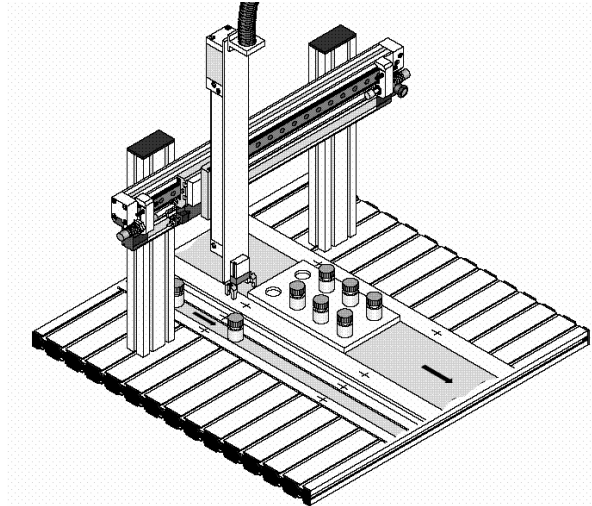

Triggering .

event

event



:(PRINTER COM)  
(Mother board)

(Programmable Control Interface)PCI  
( )

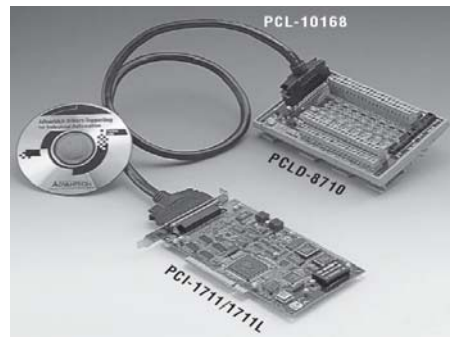

PCI-1711

(A/D)

(A/D)



سازمان فناوری اطلاعات  
سازمان فناوری اطلاعات



انجمن مهندسی  
ساخت و تولید ایران



1

دانشگاه آزاد اسلامی  
واحد نجف آباد



دانشگاه آزاد اسلامی  
واحد نجف آباد

- -

( )

PLC

PLC

(A/D)

(.)



:

vb

OPIC Photo Interrupter  
/ timer

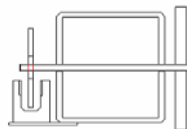
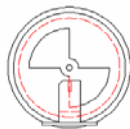

:



سازمان فناوری اطلاعات  
سازمان مهندسی



انجمن مهندسی  
ساخت و تولید ایران



1

دانشگاه آزاد اسلامی  
واحد نجف آباد  
گروه آموزشی مهندسی ساخت و تولید



دانشگاه آزاد اسلامی  
واحد نجف آباد

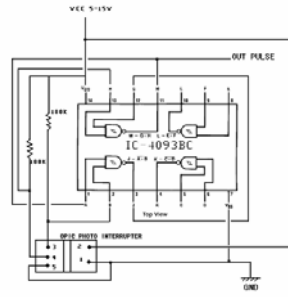

PCI



PCI



PCI

PCI 1711

(Shielded Cable)

PCI



جامعه‌ی ملی‌فناوری‌های  
سخت‌افزار



انجمن مهندسی  
ساخت و تولید ایران



1



دانشگاه آزاد اسلامی  
واحد نجف آباد

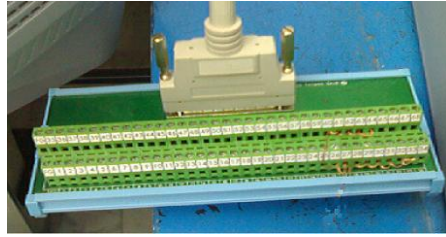

A/D Soft

VB

VB

PCI

CATIA

Assembly

Part Design  
Manipulator

Fix

Scene/ Image



1

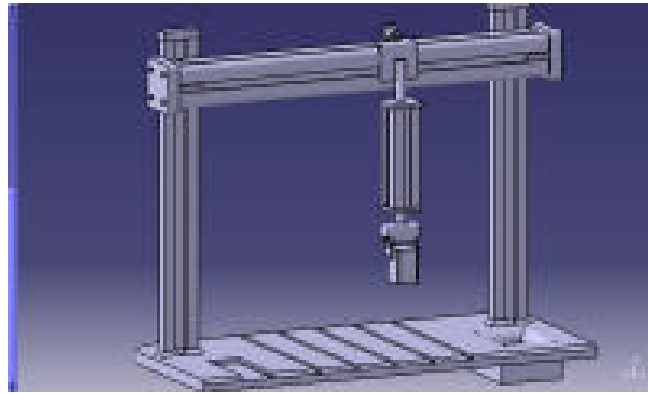

catia

VB

Visual Basic 6

Microsoft Corp

DRIVER.BAS , PCI

Add

GLOBAL.BAS

Project/ Add Module/ DRIVER.BAS, GLOBAL.BAS

VB

Frm Devsel , Frm Run

Project/ Add Form/Add existing file

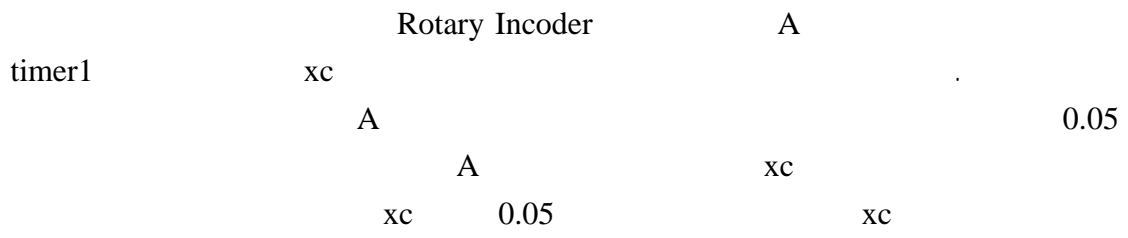

PCI

Wellcom (





Wellcom :

Load

:Simulat

:Setting

text :About Program

:Exit

Simulation (

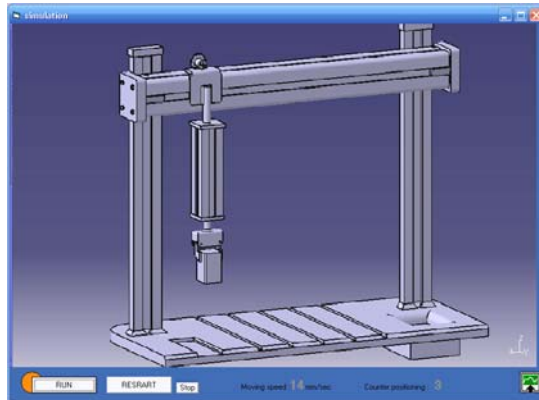

Simulation :

Load

:Run

:Restart

Image Box

simulation

:Image Window

Load

Load Picture

A

:Moving Speed

: Setting (

PCI

: Select device number

Device name

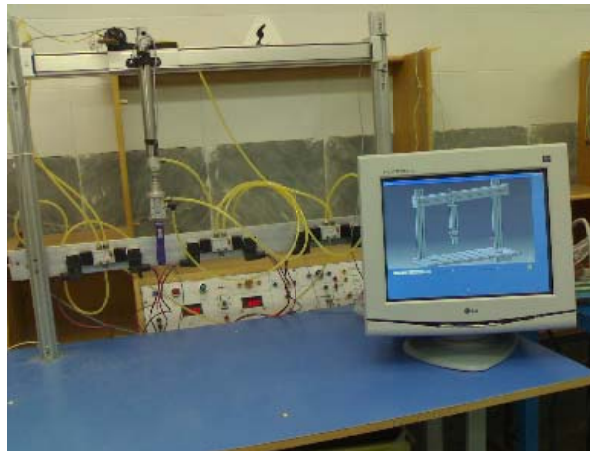
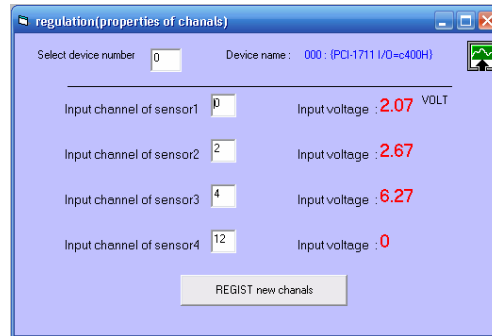

PC

PCI



دانشگاه سوادکوه  
سایت دانشگاه سوادکوه



انجمن مهندسی  
ساخت و تولید ایران

1



دانشگاه آزاد اسلامی  
واحد نجف آباد  
گروه مهندسی مکانیک و تولید



دانشگاه آزاد اسلامی  
واحد نجف آباد

burkhard kainka & hans-joachim berndt:

PC Interfaces

PC Interfaces

RS232

6. 1-Thomas O.boucher,Computer Automation in manufacturing an introduction,Department of industrial Engineering Rutgers, university Piscataway Nj usa, first edition 1996.
7. www.alldatasheet.com
8. www.national.com